

REV	BY	DATE	DESCRIPTION
---	---	---	---

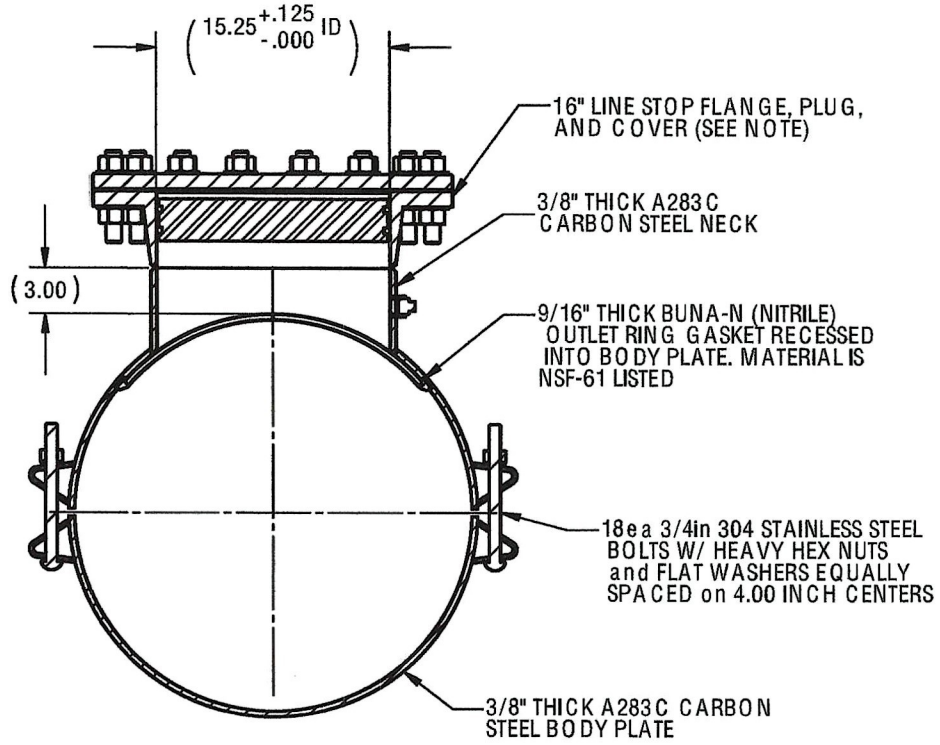

SECTION A-A

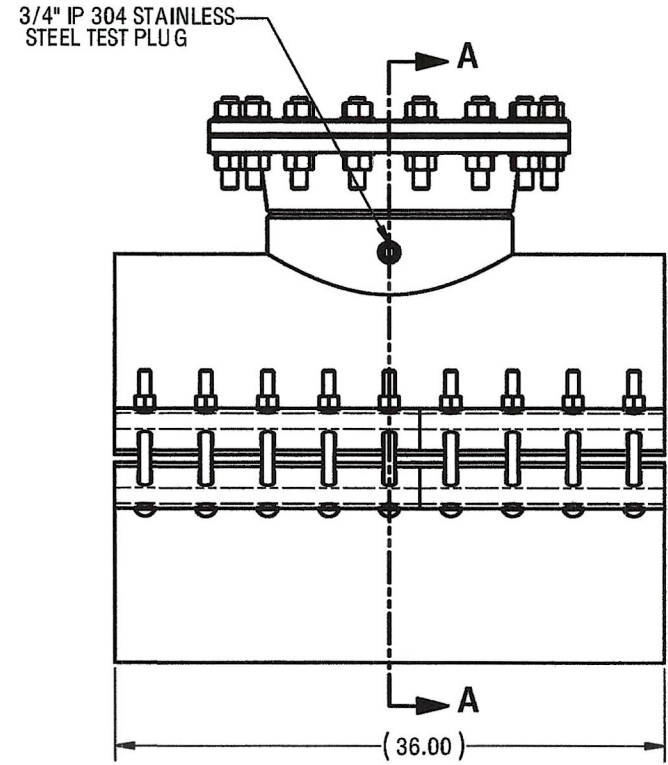

TOP VIEW

LINESTOP FLANGE = ANSI #150 WELDNECK
 LINESTOP PLUG = ASTM A36
 COVER = AWWA C207 CLASS D BLIND
 COVER HDW = ALLOY STEEL

- NOTE:
 1) MAWP = 150PSI
 2) MATP = 225 PSI
 3) FITTING MANUFACTURED TO AWWA C223
 4) FINISH = FUSION EPOXY.

TOLERANCES U.N.O. XX ±.03 XXX ±.015 FRACTIONS ANGLES ±1° MACH. FIN.	NOTES: REMOVE BURRS AND SHARP EDGES DO NOT SCALE DWG.	APP'D	DATE
	SCALE: 1:8	CK'D	DATE
ALL DIMENSIONS ARE IN INCHES.	DRN	SPRS	DATE 8/12/09

TITLE
LINESTOP 24X16
 (RANGE 25.60 - 26.00)

SMITH-BLAIR, Inc.	P/N	RPPCS2580-1616
	DWG. NO.	1 OF 1 SHEET REV.